

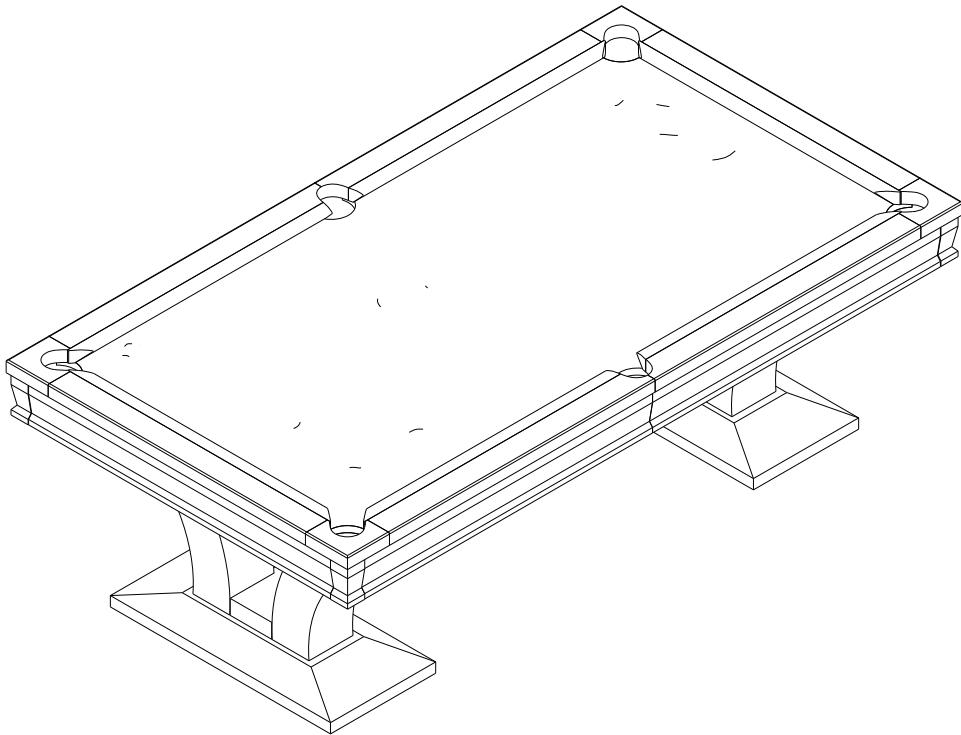



















Presidential Billiards, L.P.

HAMILTON









HAMILTON TABLE ASSEMBLY INSTRUCTIONS











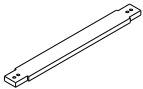

HAMILTON HARDWARE

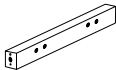
PACKAGE	ITEM#	SAMPLE	DESCRIPTION	QTY.
LEG/PANEL	H1		HEX HEAD CROSS BOLT 3/8" X 3-1/8"(M10X80mm)	4
	H2		FLAT WASHER 3/8" I.D.	4
	H3		HEX BOLT 3/8" X 5-1/8"(M10X130mm)	8
	H4		FLAT WASHER 3/8" I.D.	16
	H5		HEX NUT 3/8" I.D.	8
BEAM/BLOCK	H6		HEX BOLT 3/8" X 5-1/8"(M10X130mm)	4
	H7		FLAT WASHER 3/8" I.D.	4
	H8		NUT 3/8" I.D.	4
	H9		HEX HEAD CROSS BOLT 5/16" X 2"(M8X51mm)	4
	H10		FLAT WASHER 5/16" I.D.	4
	H11		HEX HEAD CROSS BOLT 5/16" X 3-1/8"(M8X80mm)	16
	H12		FLAT WASHER 5/16" I.D.	16
RAIL/POCKET/SLATE	H13		FLAT HEAD SCREW 1/4" X 2-3/4"(M6X70mm)	16
	H14		STUD BOLT 5/16" X 5-1/2"(M8X140mm)	2
	H15		STUD BOLT 5/16" X 3-1/2"(M8X88mm)	8
	H16		FLAT WASHER 5/16" I.D.	20
	H17		HEX NUT 5/16" I.D.	20

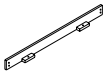
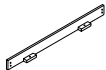
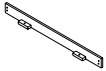

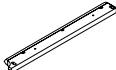
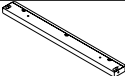

HAMILTON HARDWARE

PACKAGE	ITEM#	SAMPLE	DESCRIPTION	QTY.
RAIL/POCKET/SLATE	H18		HEX HEAD CROSS BOLT 5/16" X 1"(M8X25mm)	24
	H19		FLAT WASHER 5/16" I.D.	24
	H20		HEX HEAD CROSS BOLT 5/16" X 1-7/16"(M8X36mm)	12
	H21		FLAT WASHER 5/16" I.D.	12
	H22		HEX HEAD CROSS BOLT 3/8" X 2-3/8"(M10X60mm)	18
	H23		DOME WASHER 3/8" I.D.	18
	H24		FLAT HEAD SCREW 5# X 1/2"(M3X12mm)	24

HAMILTON COMPONENT PARTS

PACKAGE	ITEM#	SAMPLE	DESCRIPTION	QTY.
LEG	1		LEG	4
	2		LEG PAD	2
	3		LEG BEAM	1
FRAME(PANEL)/BEAM	4		SIDE CABINET	2
	5		END CABINET	2
	6		CROSS BEAM	2
	7		LEFT SIDE APRON	2
	8		RIGHT SIDE APRON	2
	9		END APRON	2
	10		APRON JOINT CONNECTOR BLOCK	2
	11		APRON JOINT CORNER BLOCK	4
	12		LONG WOODEN BLOCK	4
	13		SHORT WOODEN BLOCK	4
TOP RAIL	14		TOP RAIL LEFT SIDE	2
	15		TOP RAIL RIGHT SIDE	2
	16		TOP RAIL END	2

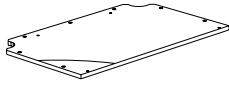
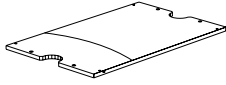
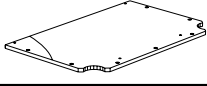
HAMILTON COMPONENT PARTS

PACKAGE	ITEM#	SAMPLE	DESCRIPTION	QTY.
	17		TOP RAIL CORNER	4
POCKET	18		SIDE POCKET	2
	19		CORNER POCKET	4
SLATE	20		SLATE (LEFT)	1
	21		SLATE (CENTER)	1
	22		SLATE (RIGHT)	1
	23		WOOD JOINT	16

HAMILTON INSTALLATION INSTRUCTIONS

FIG.1

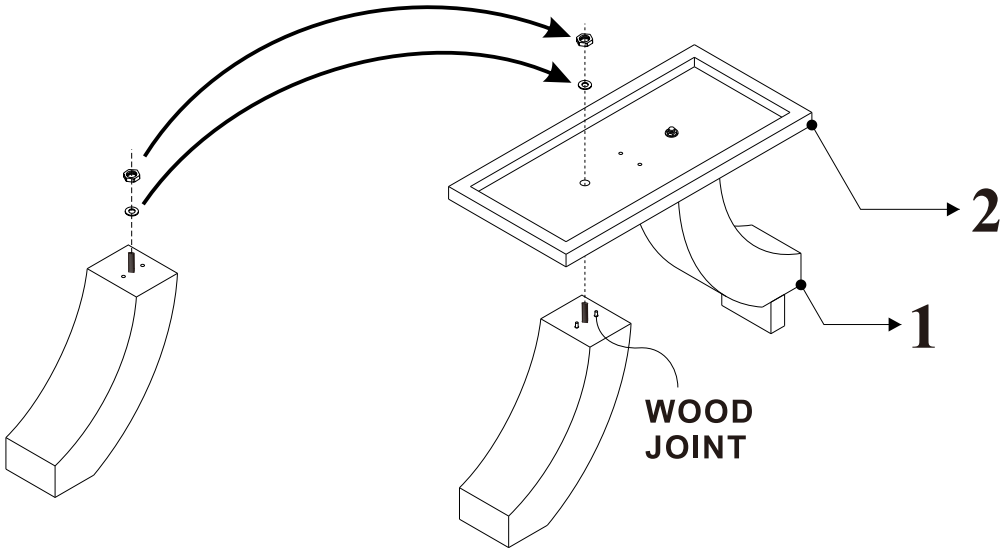
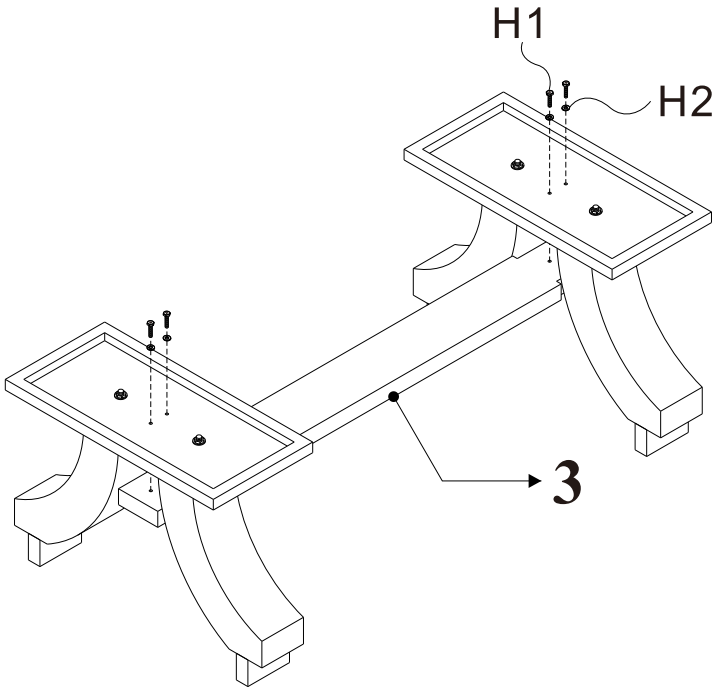

FIG.2



HAMILTON INSTALLATION INSTRUCTIONS

FIG.3

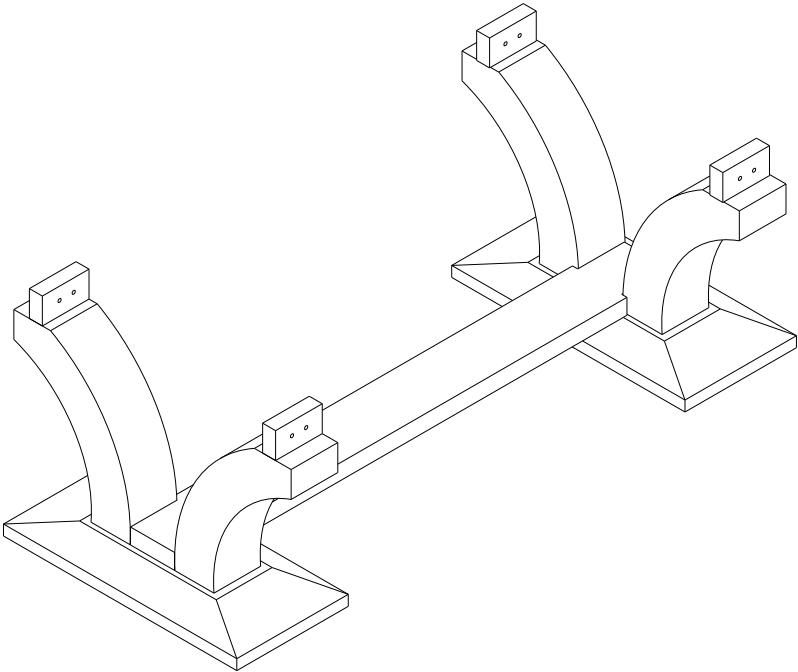
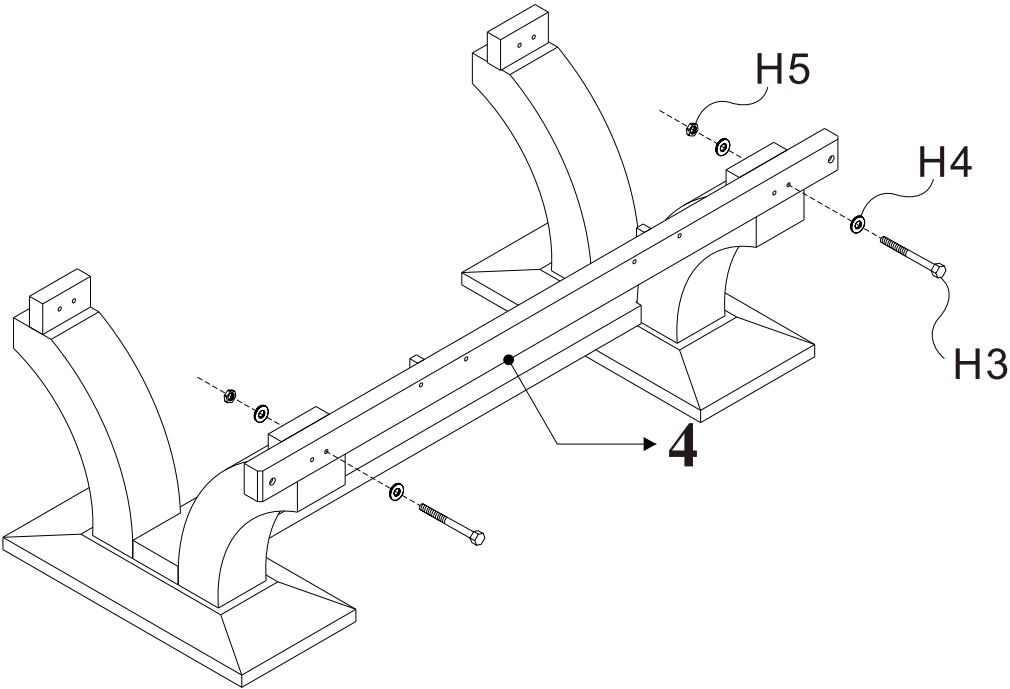

FIG.4



HAMILTON INSTALLATION INSTRUCTIONS

FIG.5

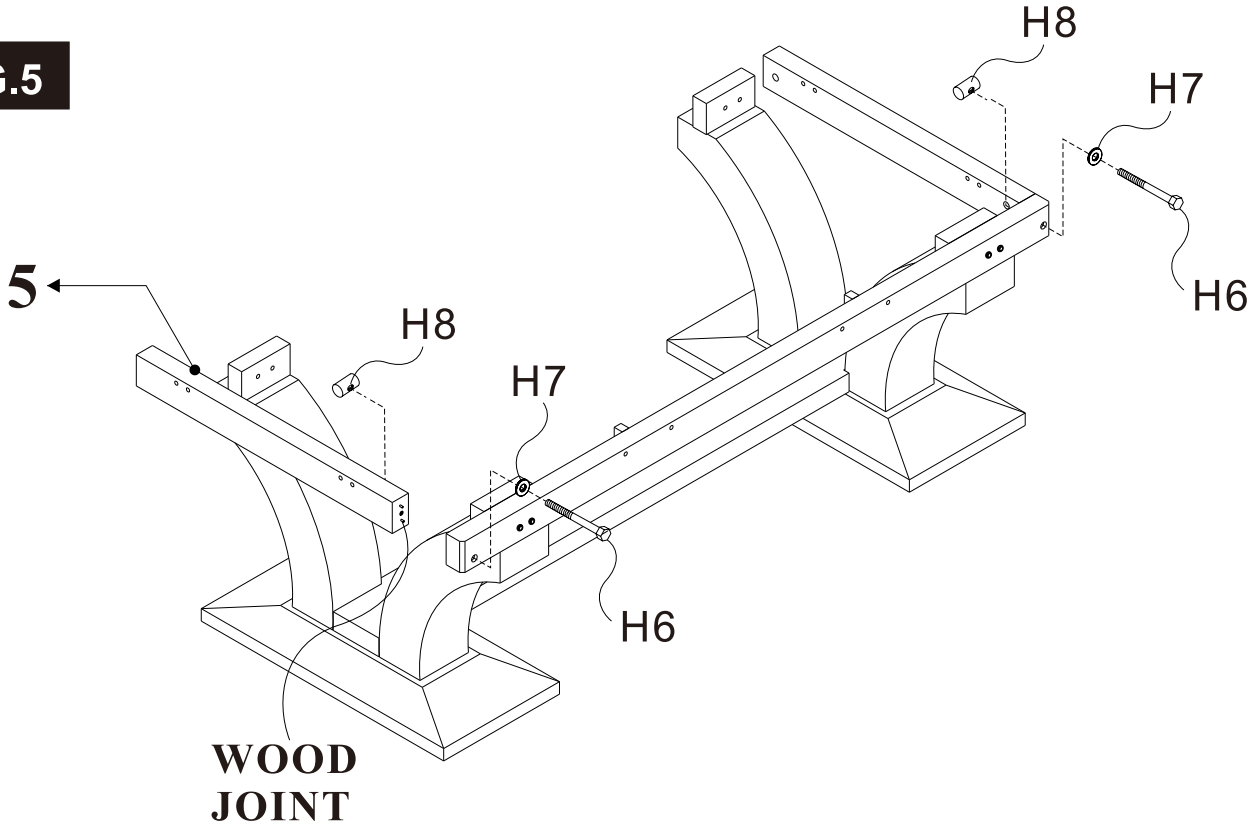
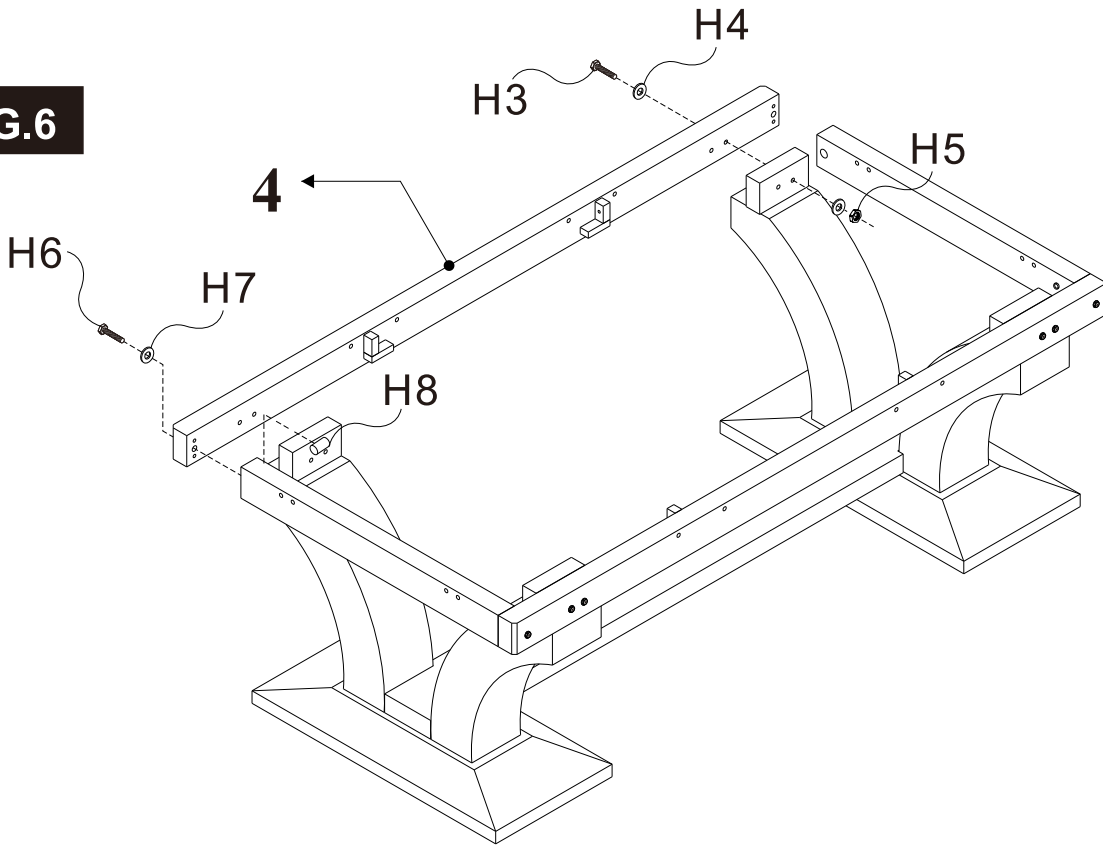

FIG.6



HAMILTON INSTALLATION INSTRUCTIONS

FIG.7

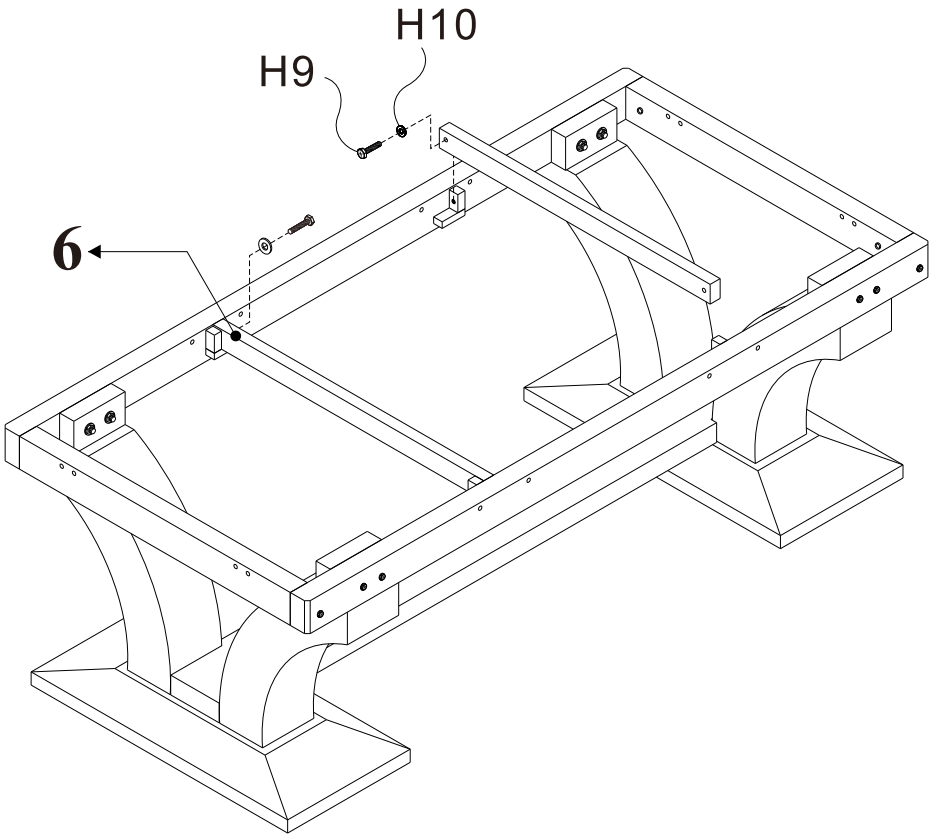
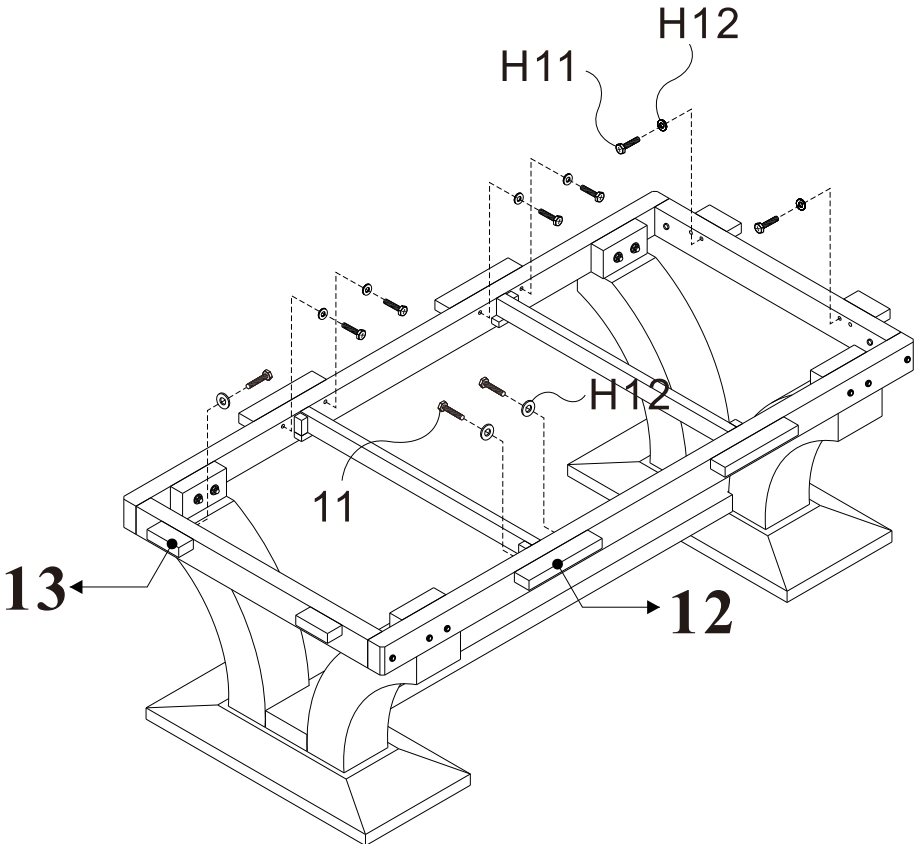

FIG.8



HAMILTON INSTALLATION INSTRUCTIONS

FIG.9

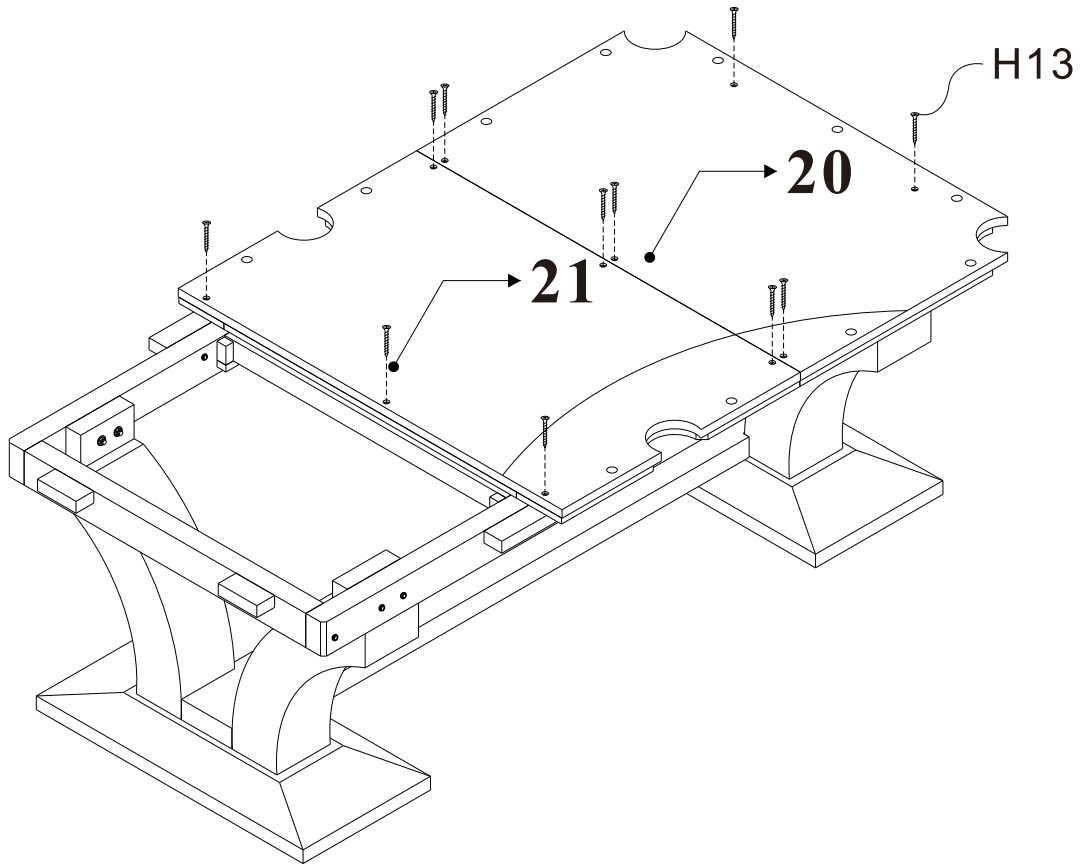
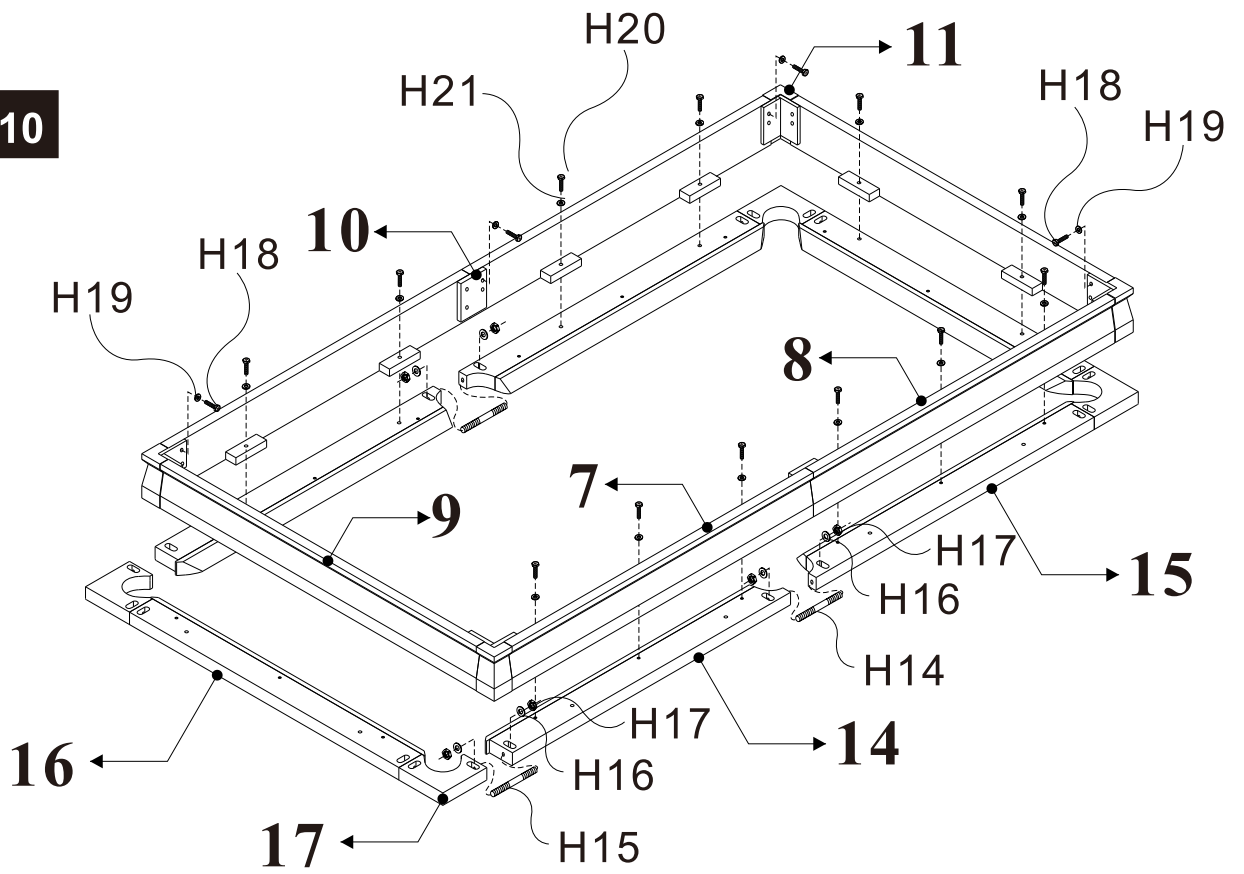

FIG.10



HAMILTON INSTALLATION INSTRUCTIONS

Cut holes in cloth at rail both locations.

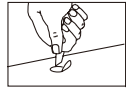
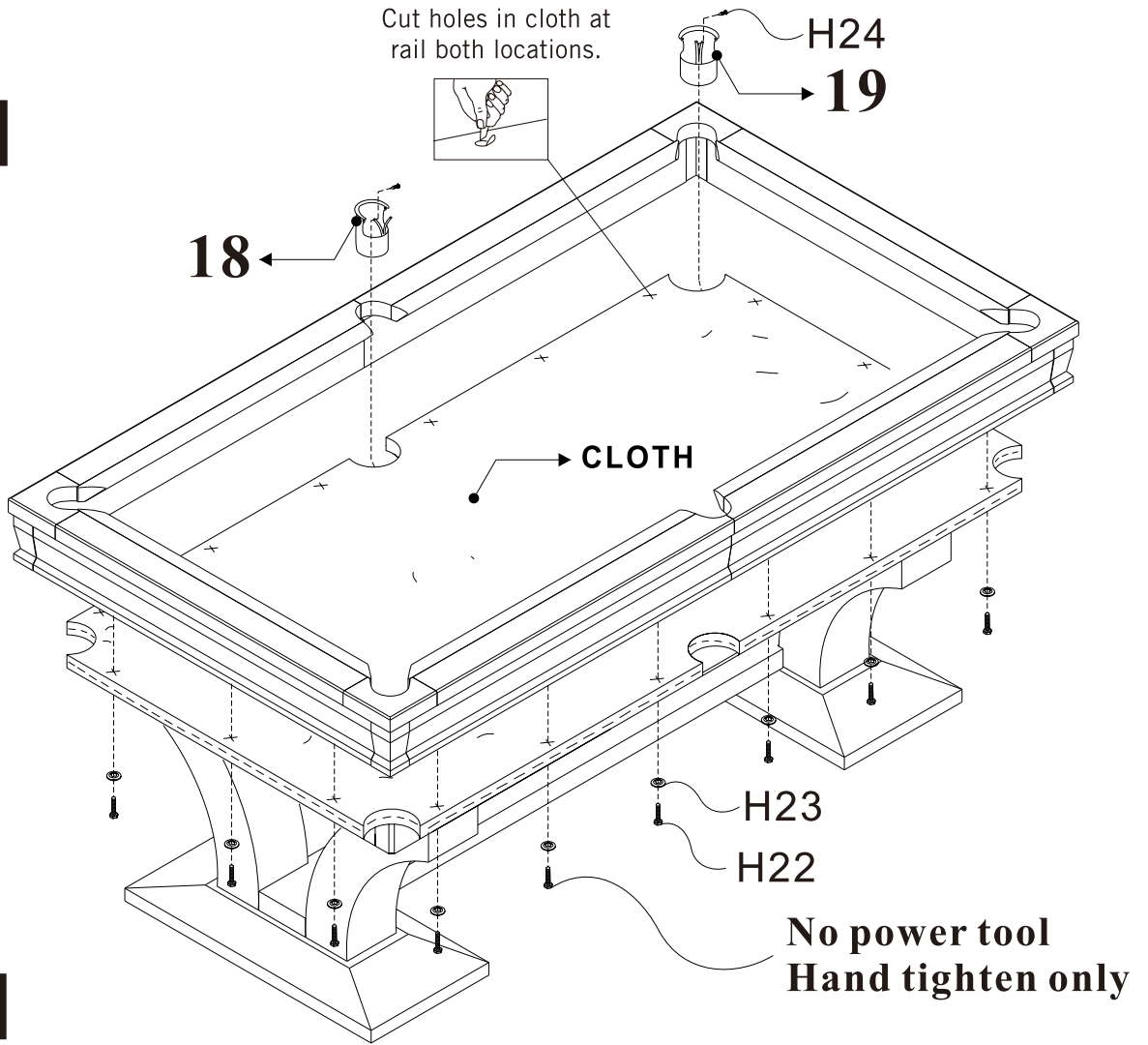

FIG.11



Finish

